



Actalyst™

Interactive Digital Signage

Touch a whole new world of possibilities

Suddenly, keeping customers engaged is simple and clear. No longer limited to static, small screen displays, you can transform your large LCD and plasma panels into interactive information stations. With Actalyst interactive digital signage, you empower customers to access customized information that you provide. Everything's right at their fingertips – gift registries, product details, directions, check-in services or event and exhibit information.

Elevate the experience

A large, vivid, interactive display attracts attention. It draws people in and keeps them involved. You enable your customers to explore at their own pace, make purchases directly and find information themselves so they don't have to ask for help. You'll be able to reach more people with fewer staff. Your customers will appreciate the choice of having instant access to relevant information that they control.

Rely on award-winning touch technology

Powered by an innovative system, the Actalyst interactive overlay provides precise touch control of your display while preserving its high image quality. Moreover, the durable, touch-friendly, anti-glare, scratch- and chemical-resistant surface protects your panel. SMART Technologies Inc. is known for its reliable touch-enabled products used in business, education, government and military applications worldwide.



"SMART's interactive overlays were exactly what we needed in terms of size, functionality and wow factor. The retail environment is very competitive and having a high-tech presence in the stores attracts customers."

*Scott Cecil
Assistant Vice President of Research, Kingsdown, Inc.
Mebane, North Carolina, U.S.A.*



Touch the interactive screen to find digital information.

Features

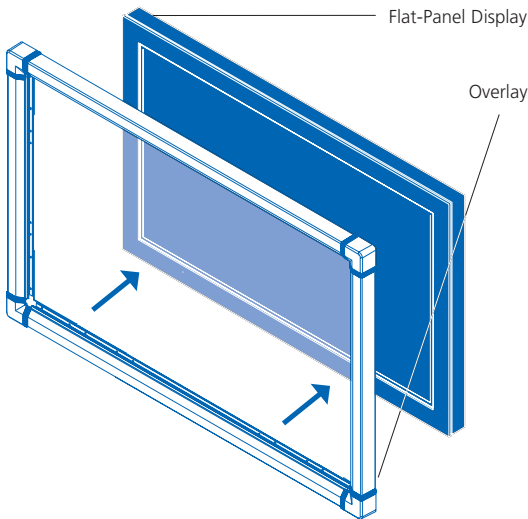

Securely attach the overlay to your display.

Touch System – DVIT™ (Digital Vision Touch) technology, developed by SMART, lets you control the display's content simply by touching it. DVIT technology uses state-of-the-art digital cameras embedded in the frame to detect contact on the screen. Touch accuracy remains consistent across the entire screen area. DVIT's durability, reliability and simplicity ensure maximum uptime for interactive stations.

Protective Surface – Durable, touch-friendly, anti-glare, scratch- and chemical-resistant surface protects your display without compromising image quality.

Size Options – Available for a wide range of flat-panel displays, in screen sizes ranging from 37 to 63" (94-160 cm) diagonals.

Supported Flat-Panel Displays – SMART's custom fit interactive overlays are compatible with large screen plasma and LCD panels from more than 17 different manufacturers. For an up-to-date list, go to www.smarttech.com/actalyst/panels.

Mounting Brackets – Four brackets make it easy to securely attach the overlay to most PDPs and LCDs.

Orientation – Choose to order the portrait or landscape installation.

Software – The driver, which provides touch control of your interactive overlay, is available for most Windows® operating systems and is compatible with content-development software.

System Requirements Windows Operating Systems

Pentium® 150 MHz processor (Pentium II processor or later recommended) • 48 MB of RAM (128 MB recommended) • Windows NT® 4.0 (SP-6), Windows 98 operating system or later • 21 MB of free hard disk space for minimum installation • Available serial or USB port (1.1 or faster)

www.smarttech.com/actalyst



SMART Technologies Inc.
Suite 300, 1207 11th Avenue SW
Calgary, AB CANADA T3C 0M5
Phone +1.403.245.0333 Fax +1.403.228.2500
Toll Free 1.888.42.SMART (Canada/U.S.)
info@smarttech.com www.smarttech.com

Authorized SMART reseller



Available exclusively from:

Presentation Products, Inc.
500 West 37th Street
New York, N.Y. 10018

www.PresentationStore.com Phone (212) 736-6350 / Fax (212) 736-6353